

CARAT 130 compact

Injection Unit

Injection Force dynamic	kN	409
Injection Force Intensified	kN	1096
Plunger Stroke	mm	850
Maximum plunger Velocity	m/s	8.38
Injection Height	mm	0/-350

Closing Unit

Maximum Locking Force	kN	13000
Ejector Force	kN	400
Ejector Stroke	mm	220
Die Height	mm	640 - 1300
Die opening Stroke	mm	1100
Smallest permissible Die Dimensions	mm	830 x 830
Maximum permissible Surface Pressure	N/mm ²	100

p/Q² Diagram

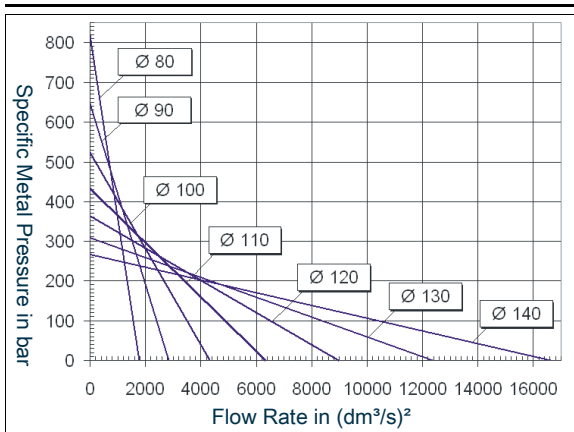

Production Data

	mm	80	90	100	110	120	130	140
Plunger Diameter	mm	80	90	100	110	120	130	140
Maximum Casting Volume	cm ³	2847	3603	4448	5382	6405	7518	8719
Maximum Casting Weight Al	kg	7.1	9	11.12	13.45	16.01	18.8	21.8
Maximum Metal Pressure	bar	2182	1723	1396	1153	969	826	712
Maximum Projected Area	cm ²	596	754	931	1126	1340	1574	1825

Casting Weight = $\frac{2}{3}$ x Plunger Stroke x Plunger Surface x Density (Al: 2,5 kg/dm³)

Hydraulic System

Installed Load	kW	80
Maximum System Pressure	bar	210
Filling Quantity	dm ³	2000
Water Cooling	m ³ /h	2.9

Central Lubrication

Installed Load	kW	0.1
Filling Quantity	dm ³	10

Nitrogen/Piston Accumulator

Maximum idle Pressure	bar	160
Filling Quantity	dm ³	195

Nitrogen/Intensifier

Maximum idle Pressure	bar	160
Filling Quantity	dm ³	65

Simultaneous hydraulic unit

Usable volume	dm ³	24
Available accumulator pressure	bar max	200



CARAT 130 compact

Platen

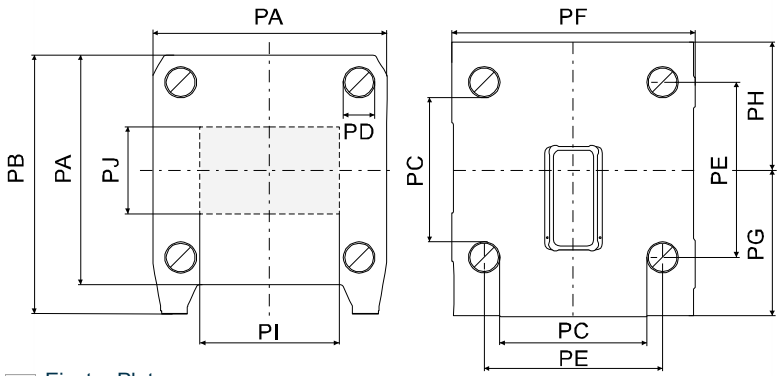

■ Ejector Plate

PA	1780
PB	2170
PC	1100
PD	220
PE	1320
PF	1780
PG	1230
PH	940
PI	1090
PJ	820
mm	

Dimension/Weight

Weight of machine ready for production = 60000 kg

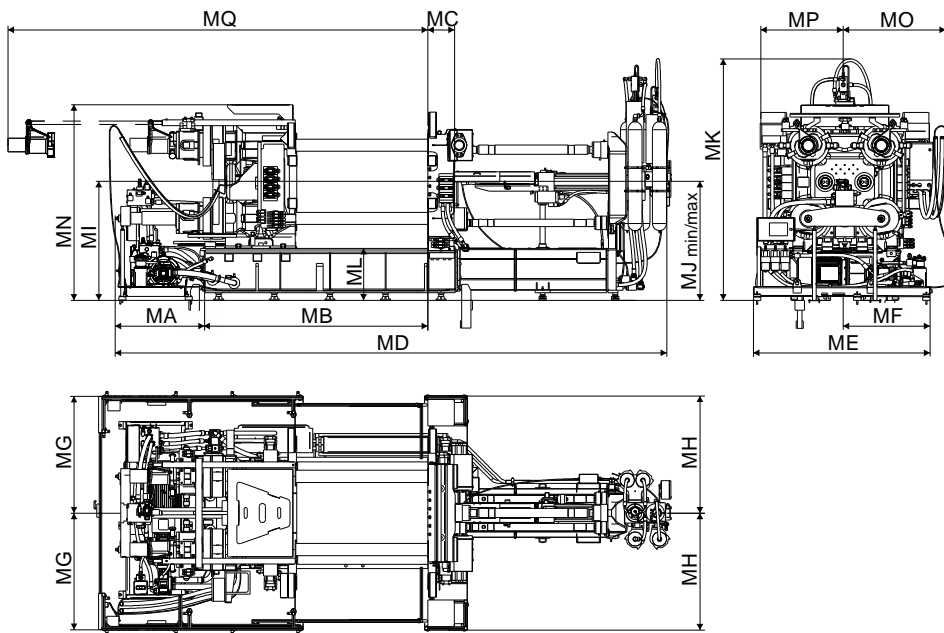

MA	1565
MB	3920
MC	480
MD	9487
ME	2900
MF	1401
MG	2020
MH	2022
MI	2042
MJmin	1692
MJmax	2042
MK	4067
ML	847
MN	3398
MO	1729
MP	1444
MQ	7593
mm	

Control

Installed Load at 400V / 50 Hz = 80 kW

P) Option 670

